

FOR APPROVAL
承认书

CUSTOMER/客户:

TYPE/类型:

TOROIDAL TRANSFORMER

PART NO./物料编号:

DRF-ZMB1049

MODEL NO./主机型号:

258.9VA

SERIAL NO./序列号:

DESIGN/编制:

APPROVAL/批准:

*AUTHORIZED SIGNATURE
& COMPANY CHOP
客户认可回签(章)*

1. ENFORCE STANDARD/执行标准

SAFETY STANDARD/安规标准: EN61558

2. ELECTRICAL PERFORMANCE/电气参量

Primary rated voltage/初级额定输入: 0~115V, 0~115V, 50/60Hz

Exciting current/最大空载(励磁)电流: 80mA (230V50Hz)

Secondary rated voltage and current/次级额定输出:

	UNLOAD VOLTAGE 空载电压(V±5%)	LOADING VOLTAGE 负载电压(V±5%)	RATED CURRENT 额定负载电流(A)
5-6	0-688.9V	0-650V	0.18A
7-8	0-370.88V	0-350V	0.18A
9-10	0-5.4V	0-5V	3.0A
11-12	0-5.4V	0-5V	3.0A
13-14	0-6.83V	0-6.3V	3.0A
15-16	0-10.78V	0-10V	3.0A

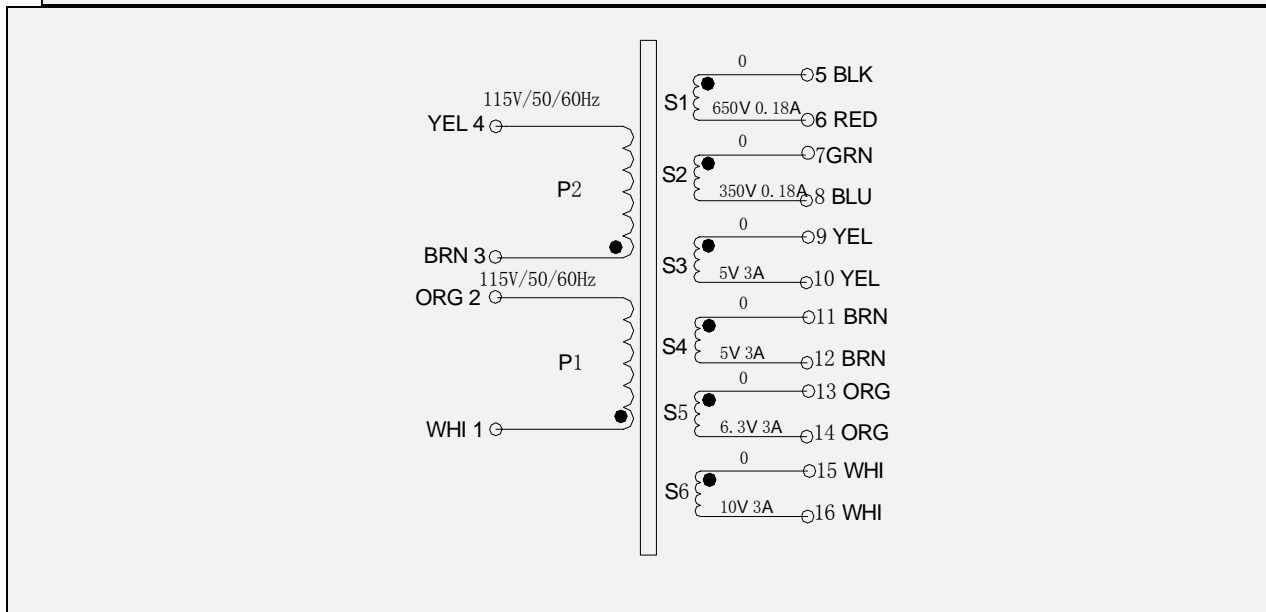
3. CIRCUIT DIAGRAM/电路图**4. WORKING AND SAFETY PROTECTION/工作防护及安全保护**

- Electrostatic Shield/静电屏蔽 Magnetic Shield/磁屏蔽
 Temperature Protection/温度保护 Over Current Protection/过电流保护

5. INSULATION/绝缘性能

Insulation resistance test (type test) /绝缘电阻测试 (型式测试): Pri.~sec. 500V DC 100 MΩ MIN.

HI-POT TEST (100% test) /耐压测试 (100%测试): Pass our dielectric strength test, without any breakdown

Pri.~sec. AC 3.75kV for 5 seconds (leakage current 5mA MAX)

通过以下绝缘强度测试不产生绝缘崩溃, 初级对次级 AC 3.75kV 5 秒

6. TEMPERATURE RISE/温升性能

Ta=25°C Test by resistance method At rated load 4H. PRI.& SEC. WINDINGS' TEMPERATURE RISE 75°C MAX., 环境温度为 25°C 电阻法测试 额定负载 4 小时, 初次级绕组最大温升为 75°C。

7. MAJOR MEASUREMENT FACILITIES/主要测量设备:

HI-POT TESTER (高压机): CJ2670	INSULATION-RESISTANCE METER(绝缘电阻表): ZC-7
VOL TMETER (电压表): T19-V	DC-RESISTANCE METER (直流电阻表): QJ44
AMPEREMETER (安培表): T19/1-A	

LEADS/引线	PRIMARY/初级		SECONDARY/次级					
LEAD NO./引线序号	1-2	3-4	5-6	7-8	9-10	11-12	13-14	15-16
COLOR/颜色	白/WHI-橙/ORG	棕/BRN-黄/YEL	黑/BLK~红/RED~	绿/GRN 蓝/BLU	黄/YEL~黄/YEL	棕/BRN~棕/BRN	橙/ORG~橙/ORG	白/WHI~白/WHI
SPECS/规格	UL1015 AWG#20	UL1015 AWG#20	UL1015 AWG#20	UL1015 AWG#20	UL1015 AWG#20	UL1015 AWG#20	UL1015 AWG#20	UL1015 AWG#20
LENGTH/长度 (±10mm)	200	200	300	300	300	300	300	300
TERMINAL/线端	5mm扭绞上锡		5mm 扭绞上锡					

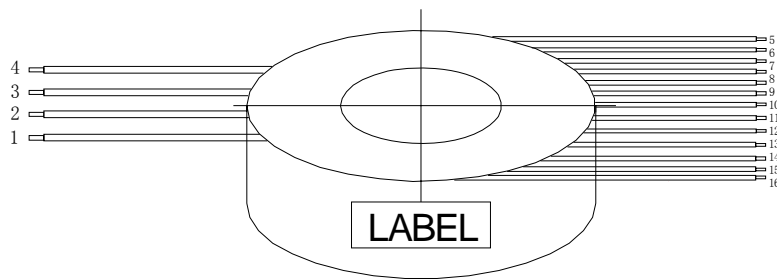

OD≤155mm(出线位)
HT≤68mm

LABEL/标签	WEIGHT/重量		ACCESSORIES/附件		±
ZMB1049 258.9VA PRI: 0---115V, 0---115V - 50/60Hz (WHI-ORG) (BRN-YEL) SEC: 0-----650V 0.18A (BLK--RE) 0-----350V 0.18A (GRN--BLU) 0-----5V 3A (YEL---YEL) 0-----5V 3A (BRN---BRN) 0-----6.3V 3A (ORG--OR) 0-----10V 3A (WHI--WHI) production date:19/06/12 Foshan Zhongming Electronic Industrial Co.,Ltd	1	METAL WASHER/环牛盖	Φ8.5*90MM	1PCS	
	2	RUBBER WASHER/橡胶垫	Φ8.5*100MM Φ8.5*130MM	各 1PCS	
	3	SCREW/螺栓	M8*70MM	1PCS	
	4	HEX NUT/螺母	M8	1PCS	
	5	WASHER/平垫	M8	2PCS	
	6	LOCK WASHER/弹垫	M8	1PCS	

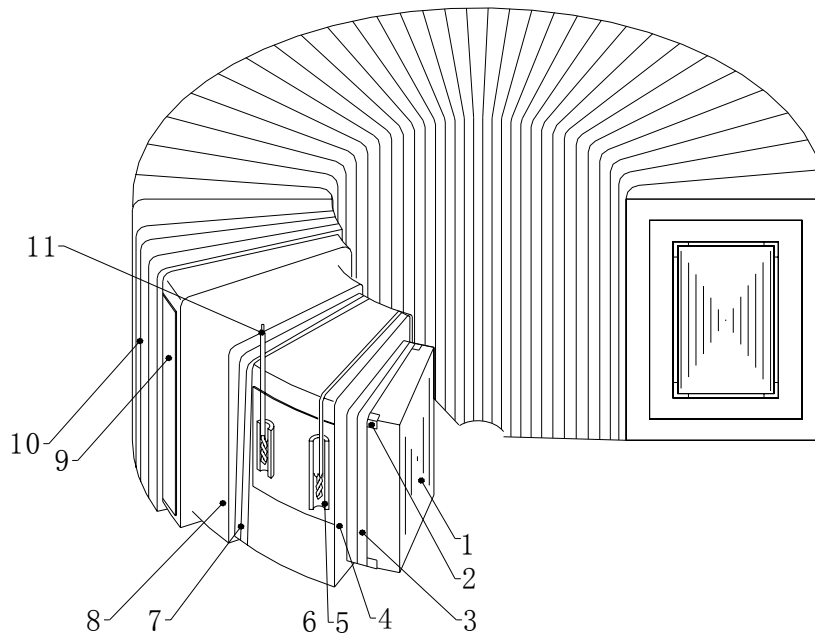

NO: 序号	DENOMINATION 名称	型号	SUPPLIERS 供应商	CERTIFICATE NUMBER 认证号(UL)	
1	Annular core 环形铁芯	Z11	Nippon Steel Corporation .or equivalent or equivalent	-----	
2	Insulation protection 绝缘保护	PET	JINGJIANG HENG HE RUBBER INDUSTRY CO LTDor equivalentt	E219145	
3	Core Insulation 铁芯绝缘	Mylar	DUPONT TEIJIN FILMS U S L P or equivalentt	E93687	
4	Pri.Winding 初级绕组	PEW MW5	ZHEJIANG XIANDENG ELECTRICALAPPLIANCES CO LTDorequivalent	E218270	
5	Outgoing line cannula 引出线护套	Srs,-40	SHENZHEN CHANGYUAN ELECTRONIC or equivalent	E233804	
6	Terminal underlay 接头垫护	0.25mm.	广州市杰丰电工器材有限公司 or equivalentt	N/A	
7	Pri.Insulation 初级绝缘	Mylar	DUPONT TEIJIN FILMS U S L Por equivalentt	E93687	
8	Sec.Winding 次级绕组	PEW MW5	ZHEJIANG XIANDENG ELECTRICALAPPLIANCES CO LTDorequivalent	E218270	
9	Insulation protection 保护胶	PZ	JINGJIANG HENG HE RUBBER INDUSTRY CO LTDor equivalentt	E219145	
10	Coating insulation 外包绝缘	Mylar	DUPONT TEIJIN FILMSUSLPor equivalentt	E93687	
11	Lead 引线	UL1015	FOSHAN ZHUO SHENG GREEN WIRE CO LTDor equivalentt	E251755	